



The Steel-Ply forming system is a pre-engineered, factory-built, reusable concrete forming system. It may be used in handset or gangform applications, for commercial or residential structures.



The Steel-Ply forming system is a pre-engineered, factory-built, reusable concrete forming system. It may be used in handset or gang form applications, for commercial or residential structures. The Steel-Ply forming system can form walls of almost any shape or size, with accessories for special structures and details. This system is more productive and economical than job-built plywood formwork or other forming methods.

Steel-Ply Saves Time

The Steel-Ply forming system saves time because it is easy to set up and strip. No measuring, sawing, drilling, or nailing is required. Minimal training is needed, so workers are quickly up to maximum efficiency. The only tool required for setup and stripping is a hammer.

Steel-Ply Saves Materials

Unlike job-built formwork, which must be tailored for each specific pour, the Steel-Ply forming system comes in a variety of standard sizes which can be combined to form virtually any dimension. Steel-Ply panels and fillers are made of specially laminated plywood mounted on rugged steel frames. They can be used up to 200 times before being re-plyed.

Quality, Consistency and Safety

No matter what the application, the same basic components and methods are used. Labor performance becomes consistent and predictable, and the laminated plywood panels and tight-fitting side rails produce a high quality concrete surface. This engineered system is designed and manufactured with a known strength factor, a major consideration for jobsite safety.

Superior Service

The complete Steel-Ply forming system is available through a worldwide network of Symons Branches, Dealers and Distributors. Each Branch and Distributor is staffed with Symons representatives who are trained and experienced in concrete forming. These representatives can work with you to develop detailed formwork layout drawings which show component placement and reuse cycles. This includes a complete bill of materials to ensure that all essential elements are available when the job starts.

On-the-job crew training, application consultation, Safety Sheets and Application Guides are also available. This extra assistance helps crews work rapidly, efficiently, and safely during the project.

Rent or Purchase

All standard panel sizes and most accessories are available for rental or purchase. This is especially advantageous if you have an unusually large or unique job where purchasing a system is not practical. Another option is to buy the basic panels and accessories and rent some of the specialized components as the need arises.

Let a Dayton Superior representative prepare an analysis to determine if the rental or purchase of the Steel-Ply forming system is appropriate for the specific application.

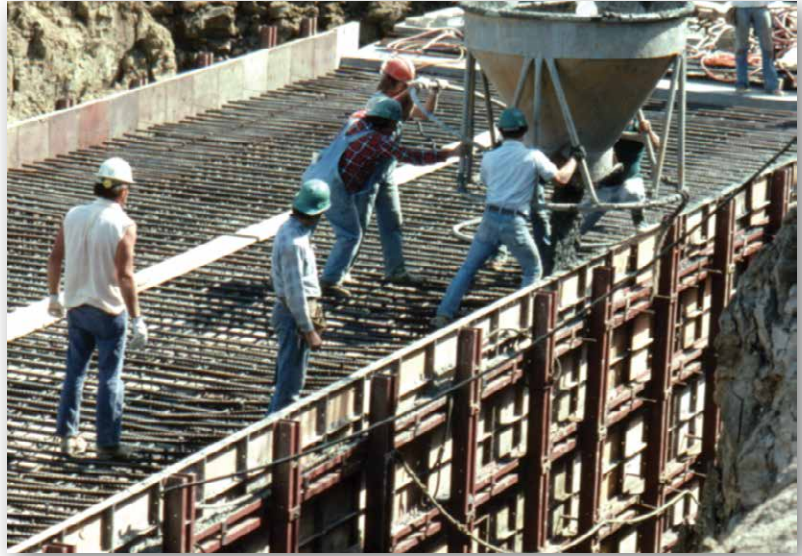



System Design

Steel-Ply panels and fillers are constructed from a rugged steel frame. The side rail of the form is rolled exclusively for Symons and has a minimum yield stress of 55,000 psi. Crossmembers have a minimum yield stress of 60,000 psi and are located at one foot centers on all panels and fillers.

Symons special 1/2" 100/30 High Density Overlay (HDO) plywood provides a smooth finish. Each piece is edge sealed to repel moisture and prevent delamination. With proper care, contractors can expect up to 200 reuses before plywood replacement.

Steel-Ply requires little training because it has no top or bottom, left or right, and can be used vertically or horizontally. Dado slots at crossmembers simplify tie placement. Slots for hardware attachment are located between crossmembers.

All Steel-Ply components combine to provide a 1000 psf rated system with a predictable safety factor over the service life of the form.

The complete Steel-Ply system consists of over -100 standard panel and filler sizes. Panel and filler heights range from 3' to 10', in 1' increments. Panel widths are 24" and filler widths range from 4" to 22", in 2" increments. A 5" wide filler and steel 1", 1 1/2", and 2" fillers are also available. Wedge Bolts connect panels, fillers and ties in one simple operation.

Steel-Ply is also available in metric sizes. Panel and filler heights range from 60 cm to 300 cm in 30 cm increments. Panel widths are 60 cm and filler widths range from 10 cm to 55 cm in 5 cm increments.



Quick-Hook Handle

The Steel-Ply panel is also available with a patented Quick-Hook Handle design. This exclusive design meets the Occupational Safety and Health Administration (OSHA) requirement for fall protection (Subpart M).

The Quick-Hook Handle is integral to the panel design with staggered locations between the crossmembers. This provides convenient climbing and attachment points for personal safety equipment. This design improves worker safety without any reduction in productivity.

The same Quick-Hook Handle is used to carry the panel. The design provides enough clearance for hands, but does not interfere with panel stacking for storage.

When a Quick-Hook Handle is not accessible, the installation of Safety Eyes on any Steel-Ply panel allows easy attachment of personal safety equipment. Safety Eyes are attached to vertical siderails to provide safe climbing points on gang form applications.





Typical Wedge Bolt Connection

For productive setting and stripping of forms, Symons offers a variety of connecting hardware.

Wedge Bolts

Two identical Wedge Bolts function as a lock-bolt set, one as a connecting bolt, the other as a clamping wedge. At typical siderail-to-siderail connections, the loop end of the tie is positioned in dado slots and is secured by the same Wedge Bolts.

For typical walls, form connecting Wedge Bolts are only required at standard tie connection positions. Additional Wedge Bolts are utilized at other positions for attachment of walers, scaffold brackets or other accessory components.



Long Bolt Connection

Long Bolts

The Long Bolt is designed to be used with the 1", 1½" and 2" Steel Filler. The long connecting bolt is punched with two ¼" holes to accommodate a 16d nail to be used to shorten the bolt for Steel Fillers. A vertical Wedge Bolt secures the two panels and filler through the adjoining side rails.

Adjustable Long Bolts

The Adjustable Long Bolt is designed to allow two steel fillers to be used side-by-side. It can accommodate up to a 3" combination (i.e. two 1½" steel fillers, or a 1" with a 2" steel filler).

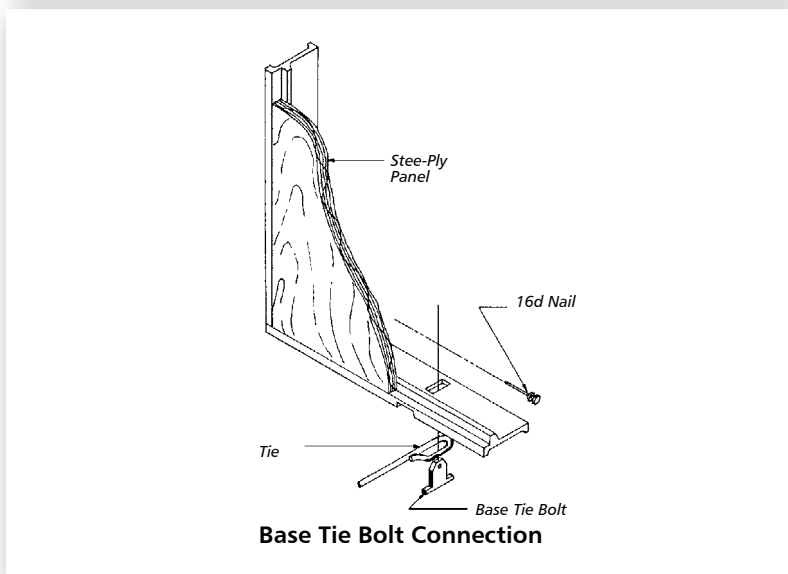

Base Tie Bolt Connection

Base Tie Bolts

The Base Tie Bolt secures a tie to an endrail or a siderail resting on a footing. It also can be used in situations where panels butt against an existing vertical surface.

Symons has the largest selection of standard and special ties in the industry. Wire ties and flat ties are used for standard Steel-Ply tie spacing, and reusable load-gathering She-Bolts and Taper Ties are used for wider tie spacing.

S-Panel Ties

The S-Panel Tie, or wire tie, is the most commonly used tie for commercial and industrial structures. The standard breakback for the S-Panel Tie is 1", with other breakbacks available upon request. The S-Panel Tie can be manufactured to almost any length, with optional cones and water resistant washers to meet job specifications.

X-Flat Ties

X-Flat Ties are commonly used for residential foundations when the 1" standard breakback is not required. The end of the tie extends beyond the back of the form for quick inspection of tie location.

Threaded Ties

The Threaded Tie provides adjustment advantages for battered walls. Threaded Ties have a special thread design to gain maximum strength using the maximum diameter thread possible with Symons standard wire tie.

S-Base Tie

The S-Base Tie has an upturned loop at each end which projects up through the bottom rail. Wedge Bolts are inserted through the loop end to secure the tie and panel. The S-Base Ties are used for small retaining walls or against existing walls.

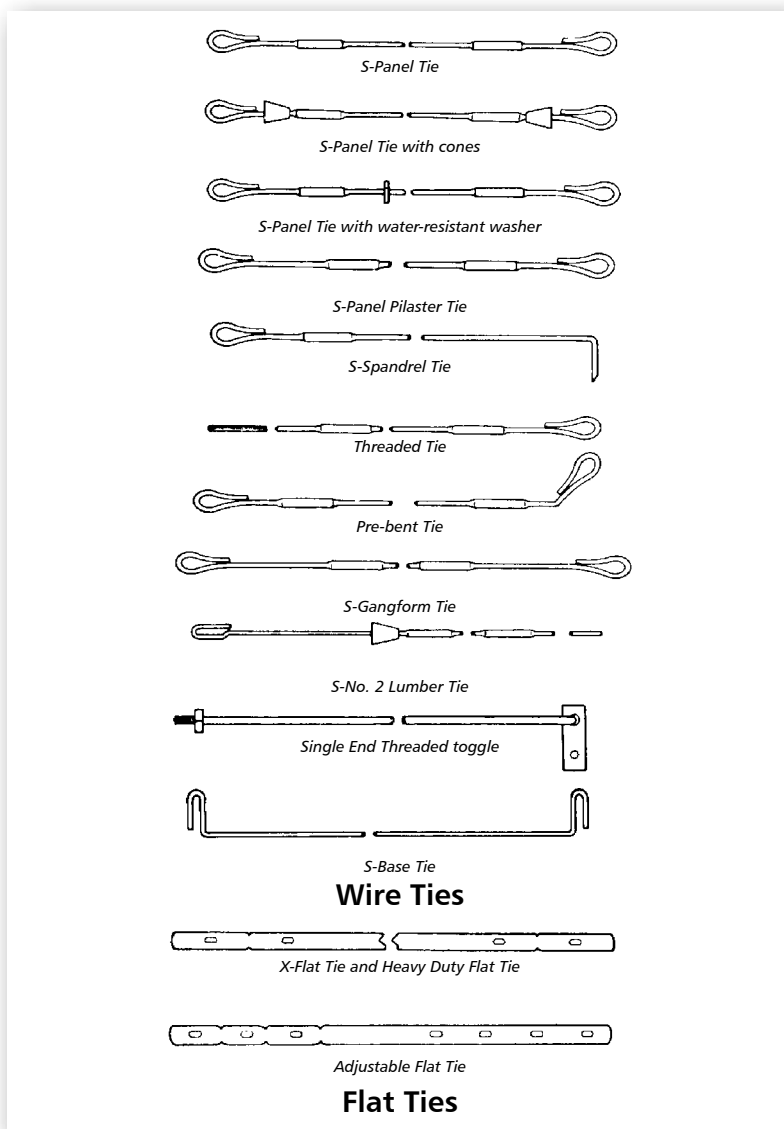

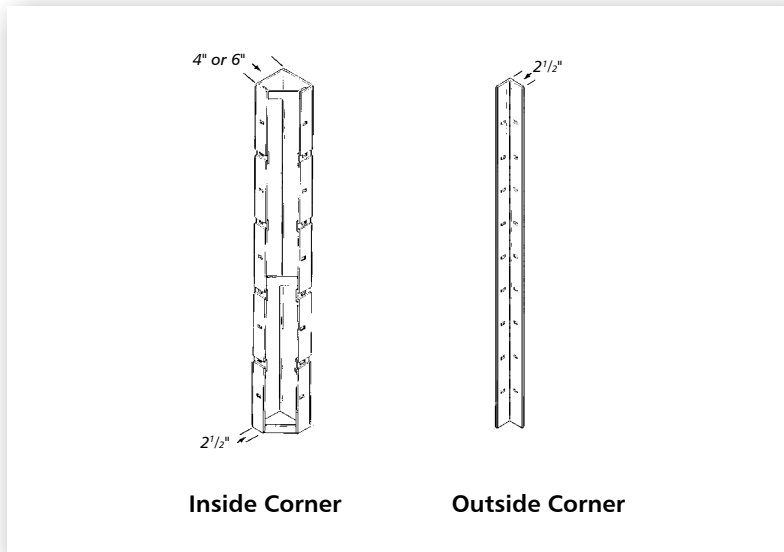

Inside and Outside Corners

Inside and Outside Corners are all-steel corners that lock adjoining forms together to make a 90° angle.

Standard Inside Corners have a face dimension of 4"x4" or 6"x6". Each Inside Corner is manufactured with reinforcing straps to maintain 90°. Dadoes are placed 12" O.C. for tie connection and slots are placed 12" O.C. for connecting hardware.

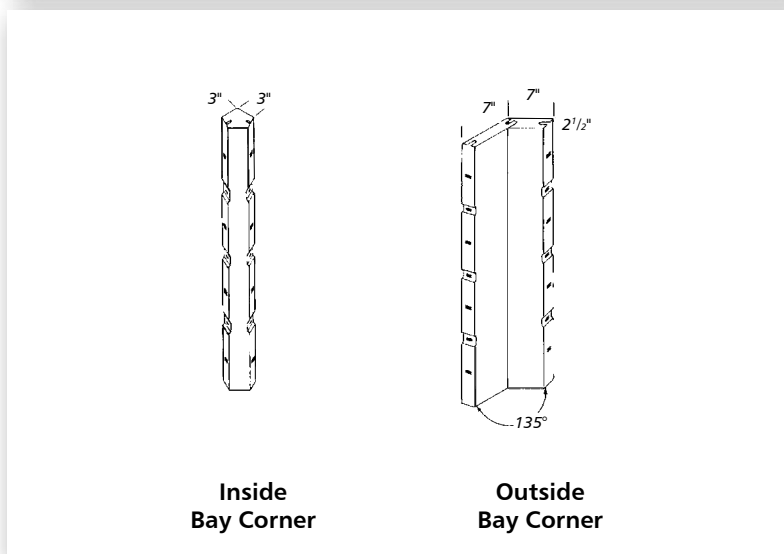

Bay Corners

Inside Bay Corners opposite Outside Bay Corners form a 135° angle.

The Inside Bay Corner has a 3"x3" face dimension, and the Outside Bay Corner has a 7"x7" face dimension. Ties connect at adjoining panel joints to complete this forming detail.

Bay Corners can also be used horizontally to form wall haunches and "Y" walls.

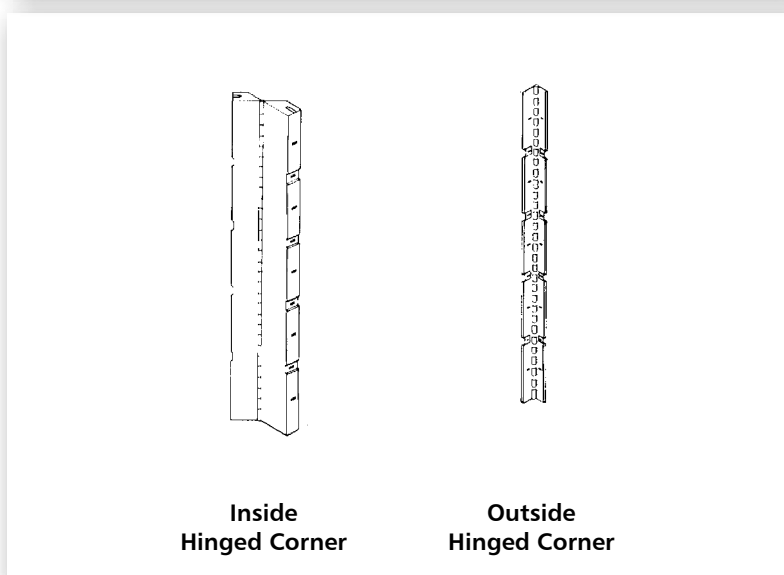

Hinged Corners

The Inside Hinged Corner may be used to form inside corners down to a 45° angle. The Outside Hinged Corner forms outside corners from 135° down to a 5° angle.

In most wall applications, Inside Hinged Corners are used opposite Outside Hinged Corners. Always insert connecting Wedge Bolts toward the adjoining panels so that the angle will not be restricted.

Corners must always be adequately waled, braced and blocked as required.

45° Bay Corner Bracket

The 45° Bay Corner Bracket (Patent #5,044,601) can be used in place of the 7"x7" Bay Corner. Two appropriately sized fillers are connected to form the outside 135° angle.

The strength of the panel design makes a waler necessary for alignment only, it is not a structural part of the formwork. Only one row of 2"x4" walers on each tier of panels is required, with a variety of time and material saving attachment options available to increase your productivity.

One-Piece Waler Bracket

The One-Piece Waler Bracket is fast and simple to install. Just insert the Waler Bracket into any siderail hole not being used for ties, place a single or double 2"x4" piece of lumber on top of the bracket, and drop the attached wedge into position. No additional hardware is needed.

Z-Tie Holder

The Waler Tie and Z-Tie Holder combination is another method of attaching walers. Waler Ties are available in two lengths to secure double 2"x4" or double 2"x6" lumber walers. Once the Waler Tie is fastened with Wedge Bolts, the lumber is positioned and the Z-Tie Holder is used to complete the assembly.

Strongbacks

Strongbacks are vertical alignment members that are placed at 90° to walers. The Strongbacks are used to align the walers and are commonly placed at 8' O.C. Strongbacks can be doubled 2"x4", 2"x6" or 2"x8" lumber secured with J-Strongback Hooks.

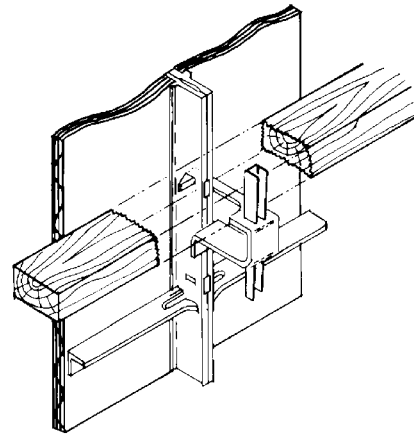

One Piece Waler Bracket Attachment

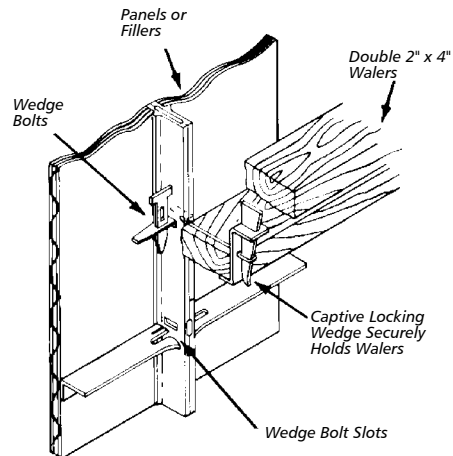

Z-Tie Holder Attachment

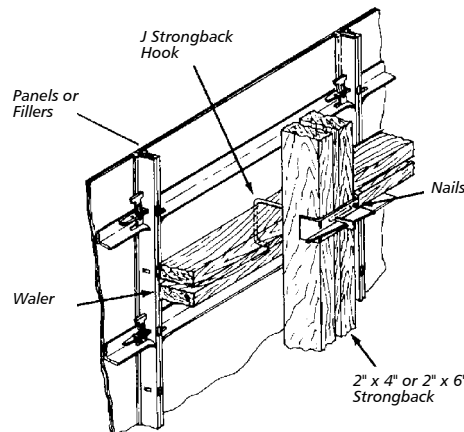

Strongback Attachment

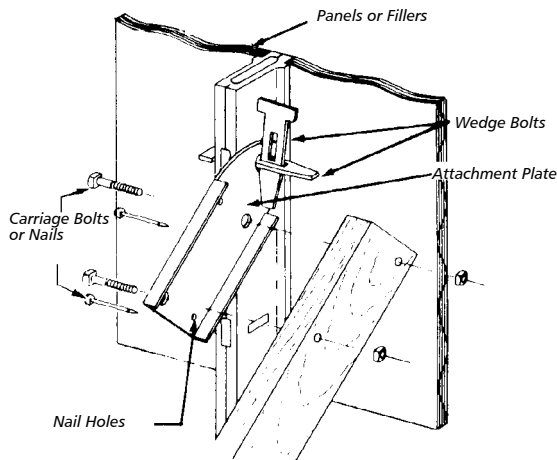

Attachment Plate Connection

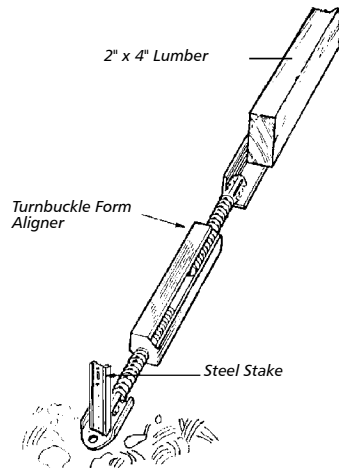

Adjustable Turnbuckle Form Aligners

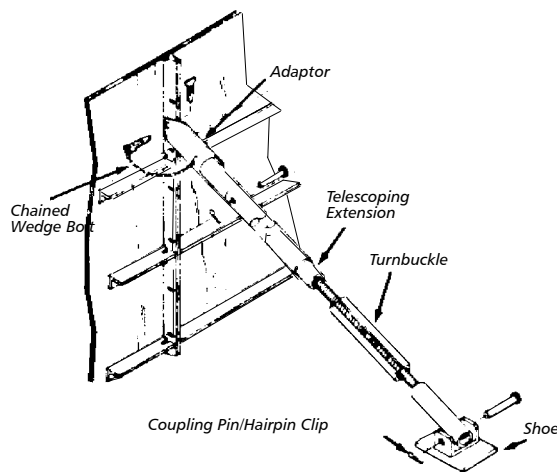

Pipe Form Aligner

Aligners are required to position forms, they are not intended to be used as bracing or to resist concrete pressure.

Attachment Plate

The Attachment Plate can be bolted or nailed to 2" x 4" lumber. Aligners are quickly attached or removed from the forms with standard connecting hardware.

Turnbuckle

Turnbuckles allow for 6" length adjustment. The Turnbuckle is attached with nails to lumber and anchored before final adjustments are made. The end of the Turnbuckle contains a large slot to accommodate a Steel Stake.

Pipe Form Aligner

The Pipe Form Aligner eliminates the use of lumber and allows adjustments from 13'-4" to 20'-9". The top end of the Pipe Form Aligner uses a Steel-Ply Adapter Plate which connects to the Steel-Ply panel. The bottom of the Pipe Form Aligner requires a Pipe Form Aligner Shoe for anchoring a 3/4" diameter concrete anchor or a Steel Stake.

Pier Cap Braces

Pier Cap Braces are available in two turnbuckle lengths and two extension tubes. Used in conjunction with the Pipe Form Aligner Shoe and the Steel-Ply Adapter Plate, they provide an adjustment range from 5'-9" to 14'-4".

Brace Kicker Bracket

The Brace Kicker Bracket has two holes for connecting an aligner and a kicker. It is used in place of the Pipe Form Aligner Shoe if a kicker is desired.

Scaffold Bracket

Scaffold Brackets are installed where one or more levels of work platform are required for personal safety. The maximum safe load of the Scaffold Bracket is 500 lbs. (4 to 1 safety factor).

The Scaffold Bracket comes with a wedge and cable attachment for quick assembly.

Note: Do not use Scaffold Brackets to support cantilevered concrete soffit forms, or for temporary storage of construction equipment or material.

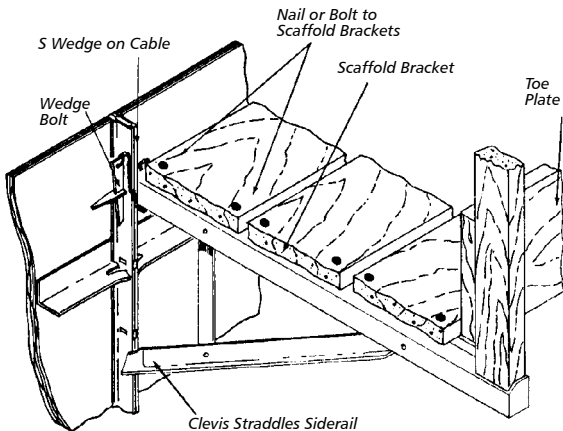

Scaffold Bracket Attachment

Filler Angle

Filler Angles provide a means to construct a custom size filler with 3/4" plywood that can be connected to the side rails of adjoining Steel-Ply forms.

These Filler Angles are recommended where reinforcing steel, pipes, or other penetrations must protrude through the form face.

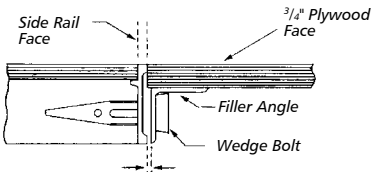
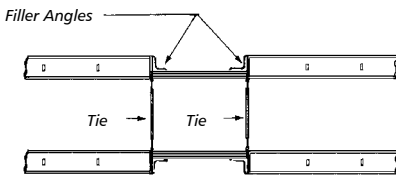

Filler Angle Attachment

Steel Filler

Steel Fillers are cold-formed U-shaped steel. The 1" and 1 1/2" steel fillers are punched with connecting slots at 6" O.C. A Long Bolt passes through the steel filler to grip adjoining panel side rails.

The 2" Steel Filler has connecting slots at 2" O.C. It is used to "step" forms in 2" increments. This steel filler reduces the need to build up under forms when step footings or changing wall elevations occur.

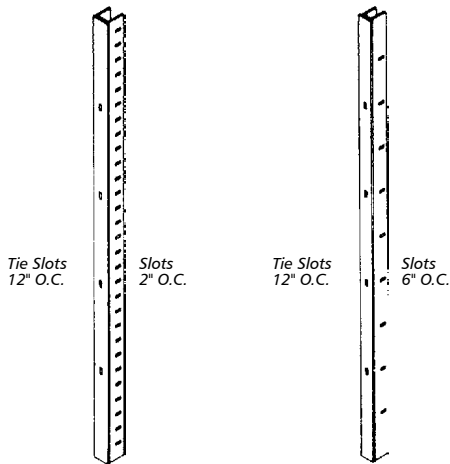

2" Steel Filler

1" or 1 1/2" Steel Filler

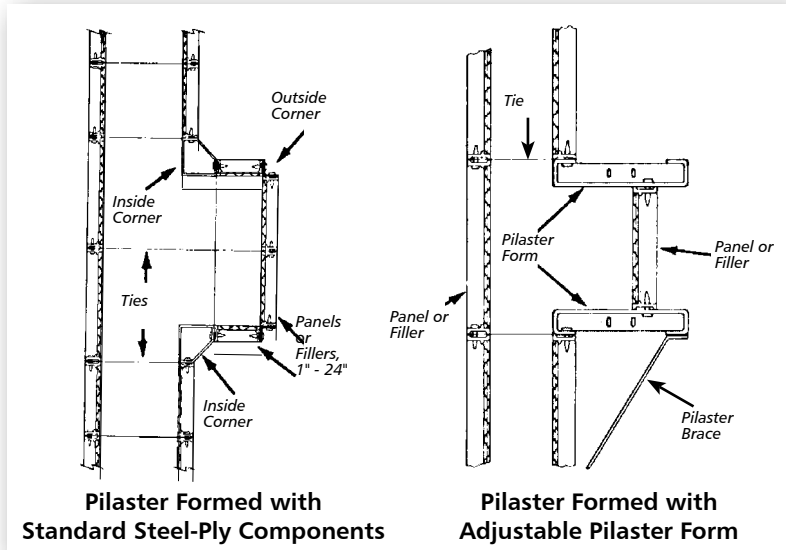

Pilaster

Pilasters of almost any dimension are formed quickly and easily using standard Steel-Ply panels or fillers with Inside Corners and Outside Corners.

Adjustable Pilaster Form

An Adjustable Pilaster Form is available to form standard pilasters from 1" to 12" deep in 1" increments. The Pilaster Form eliminates Inside and Outside Corners and the need for having specific size fillers on hand. The Pilaster Brace eliminates lumber bracing to maintain right angles.



Culvert Form

Reusable steel Culvert Forms come in chamfers sizes of 6"x6", 9"x9" and 12"x12". The Culvert Form permits monolithic pouring of the walls and elevated slab of culvert structures. The Culvert Form can also be used to make chamfered corners in vertical walls.

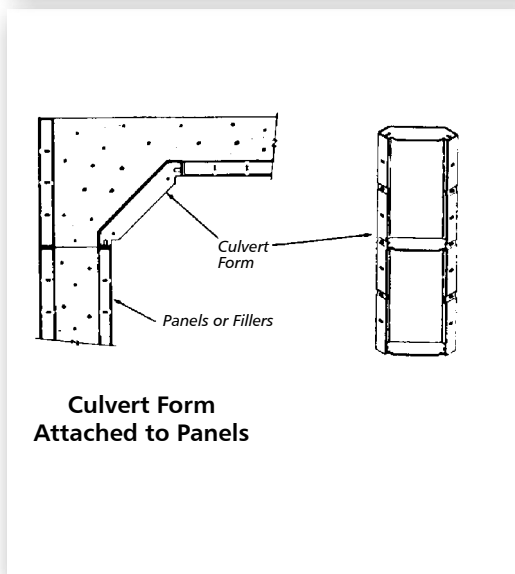

Double Duty Lift Bracket

The Double Duty Lift Bracket provides an attachment point for rigging and handling gangs. A vertical capacity of 2000 lbs. (5 to 1 safety factor) meets OSHA requirements.

Application drawings show locations and numbers of Double Duty Lift Brackets per gang.

Note: Do not break a gang form loose from a wall by lifting or tugging backwards with the Double Duty Lift Bracket.

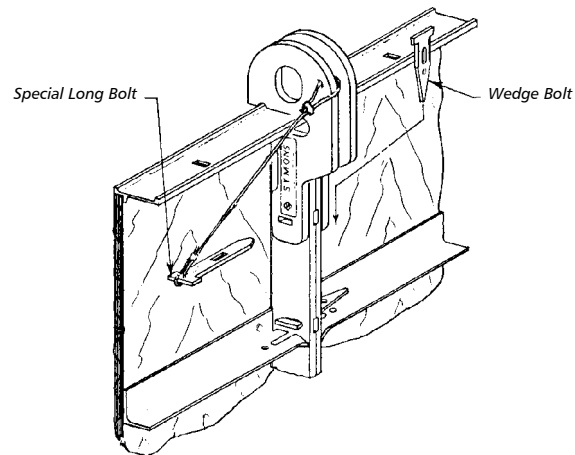

Double Duty Lift Bracket Attachment

Waler Lift Bracket

The Waler Lift Bracket is an alternative device for lifting gangs. A vertical capacity of 4000 lbs. (5 to 1 safety factor) meets OSHA requirements.

Note: Only vertical loads can be imposed at lift holes for the Waler Lift Bracket. A Lift Beam with vertical drop lines connected to Waler Lift Brackets must be used.

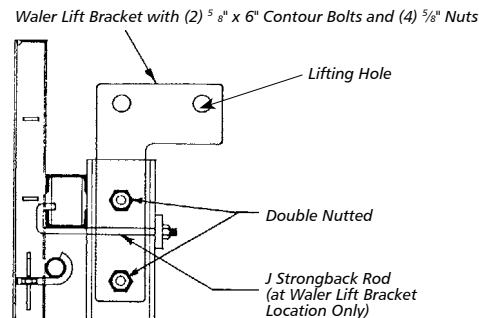

Waler Lift Bracket Attachment

Column Lift Corner

The Column Lift Corner can be used as the outside corner in the top two feet of ganged columns. The Column Lift Corner extends 4" above the column and is secured with Wedge Bolts. Two Column Lift Corners are required per column. The Column Lift Corner has a safe load capacity of 2000 lbs.

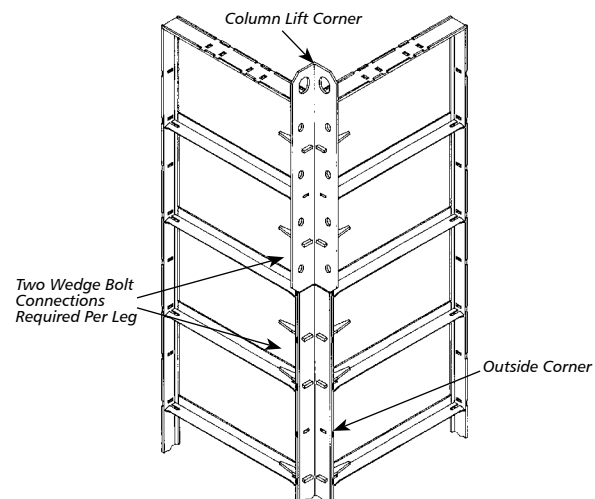

Column Lift Corner Attachment

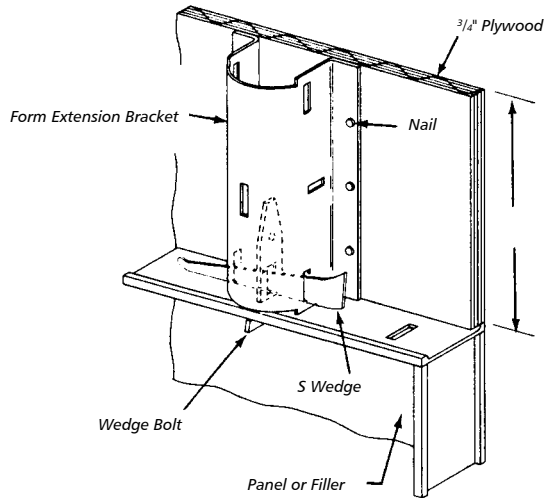

Form Extension Bracket Attachment

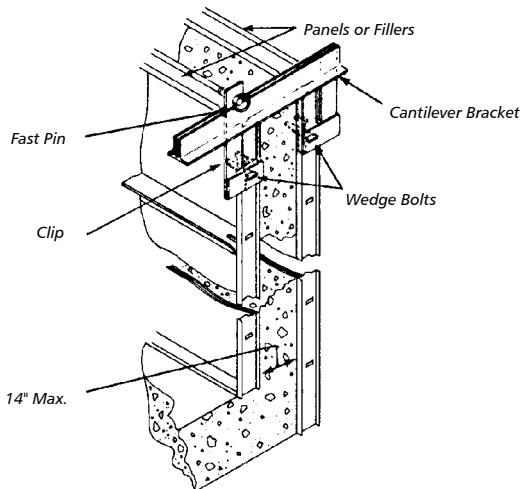

Cantilever Bracket Attachment

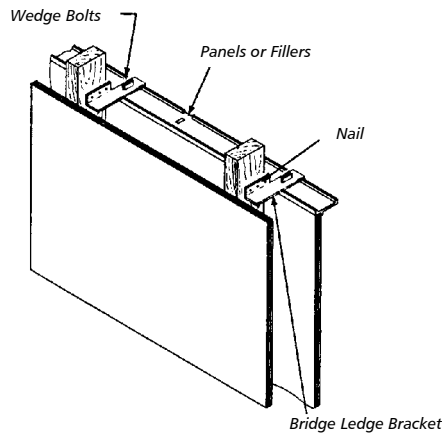

Brick Ledge Bracket Attachment

Form Extension Bracket

The Form Extension Bracket is a convenient means to extend the height of a standard panel an additional 3" to 12" for straight or curved walls. The bracket is designed to be used with 3/4" plywood and attached with a Wedge Bolt. The bolt comes up from the top rail of the panel below and is locked in with an S-Wedge. A slot in the center of the bracket allows for Waler attachment.

Cantilever Bracket

The Cantilever Bracket is used to suspend a form on the opposite side of the wall. This allows different elevations at the bottom of forms so that a base slab can be monolithically poured with the wall. Maximum capacity is 700 lbs. Maximum spacing must not exceed panel length when forms are horizontal, and must not exceed 8'-0" when panels are vertical.

Brick Ledge Bracket

The Brick Ledge Bracket is used to form brick ledges and support various framed boxouts. The bracket is attached to panels or fillers with Wedge Bolts. The bracket spans the wider side of a 2" x 4" piece of lumber to create the offset needed.

Bulkhead Forming

Keyway Forms come in 3', 4', 5', 6' and 8' lengths. When bolted to Bulkhead Bars, they produce a keyway and hold the waterstop in position.

Bulkhead bars can be used for forming bulkheads in walls 4" to 24" wide. Standard Wedge Bolts attach the bars to the siderails of panels and fillers.

Bulkheads can also be formed by using Outside Corners and a panel or filler.

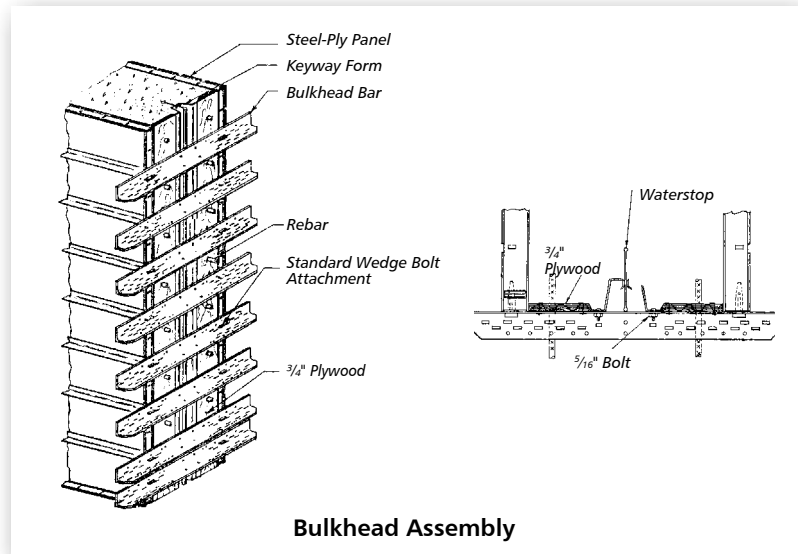

Bulkhead Assembly

Haunch Forming

Haunch Brackets provide an ideal way to form haunches or corbels, without any additional lumber support.

The Haunch Bracket connects easily with Steel-Ply® panels and is designed to support 3/4" plywood. Slots make securing walers a simple operation.

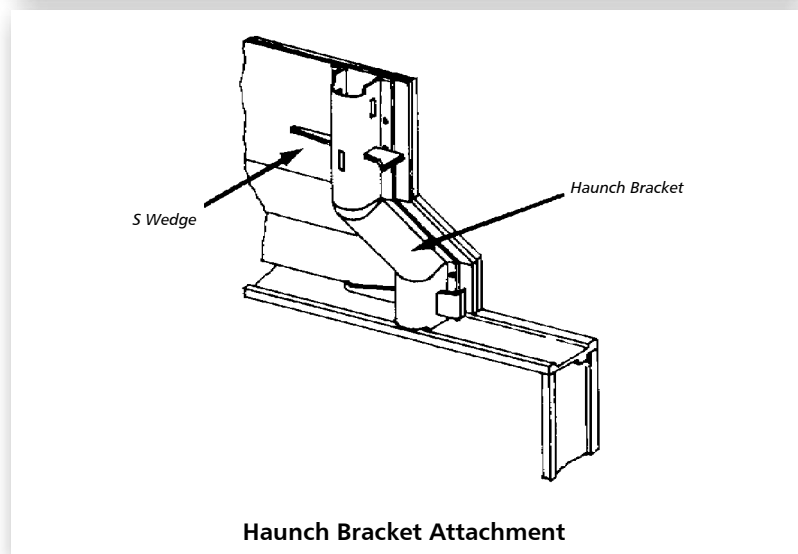

Haunch Bracket Attachment

Footing Corner Bracket

Forming footings, pads and slabs is made easy with the Footing Corner Bracket. Attached at the top and bottom of each corner, Footing Corner Brackets hold the panels firmly. A wide range of dimensions in 2" increments is possible.

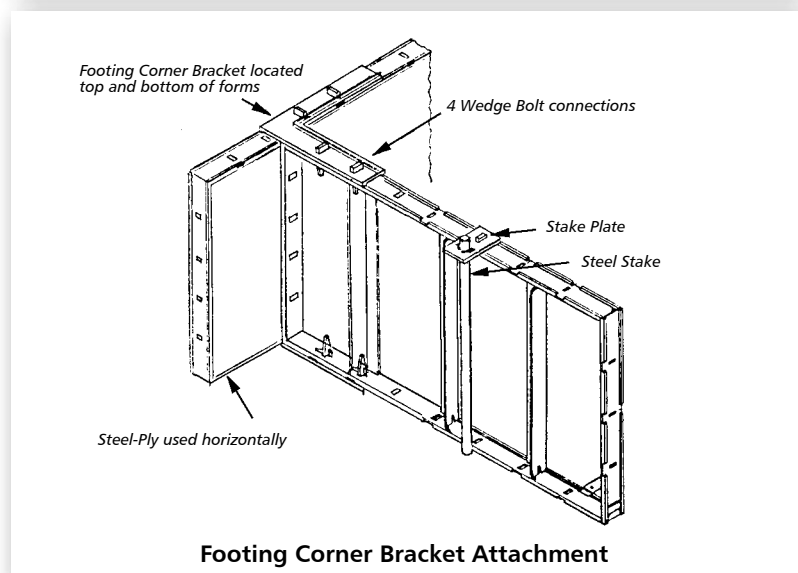

Footing Corner Bracket Attachment

Stake Plate

Stake Plates are positioned along the top edge of the Steel-Ply for Steel Stakes. The Stake Plates are typically located midway between Steel-Ply crossmembers and endrails to provide access for a stake puller.

Beam Pocket

The Beam Pocket is a reusable tapered steel boxout that leaves a void pocket at the top of the foundation wall for steel or wooden beams. The standard 6" x 8" x 4" deep size comes with a handle for easy carrying and removal.

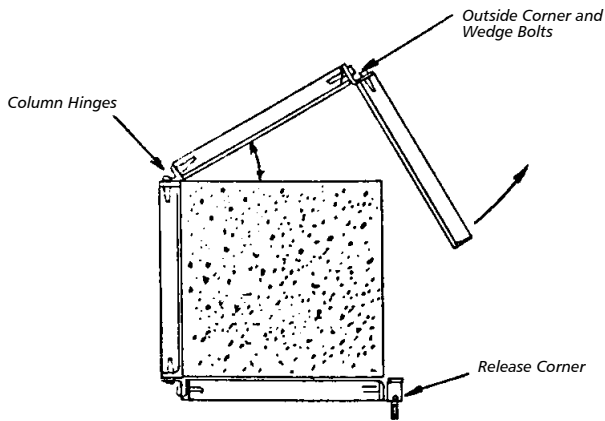

Stripping a Column with a Hinged Corner

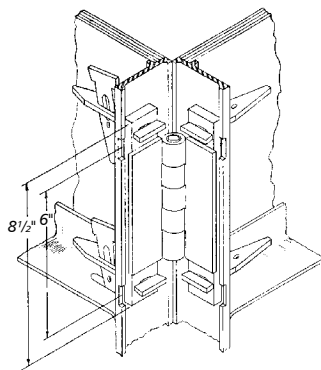

Column Hinge Corner Attachment

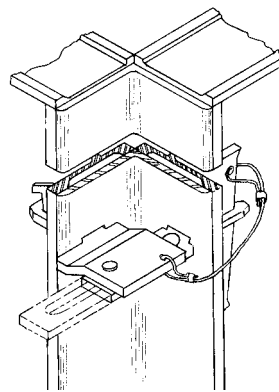

Quick Column Hardware Attachment

Note: Wedge bolts pass through plywood at selected crossmember slots

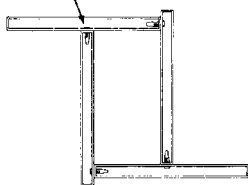

Typical Adjustable Column Form Application

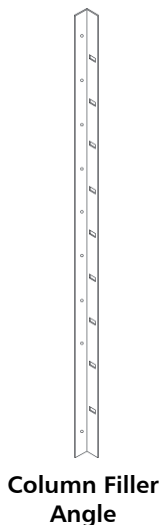

Column Filler Angle

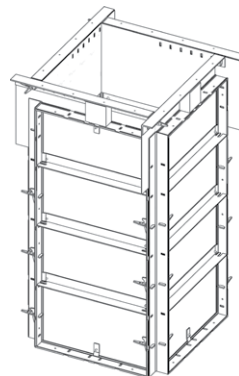

Adjustable Column Extender

Column forming

Outside Corners and panels or fillers can be combined to form square or rectangular columns.

Column Hinge

The Column Hinge helps set and strip Steel-Ply column forms efficiently. Column formwork can be handled as a single unit that is "closed" around reinforcing steel and "opened" after concrete is placed. Repetitive concrete column designs become very productive.

Quick Column Hardware

The Quick Column Hardware is used with the Column Hinge for even faster column forming. The hardware attaches to the Steel-Ply Outside Corner opposite the Column Hinge to provide a fast closure and release. Everything remains connected to the column formwork for maximum productivity.

Adjustable Column Form

The Adjustable Column Form is for columns up to 30" square, in 1" increments (except 28" and 29" increments). For columns 27" or less, panels are placed in an overlapping manner. In these instances, 3/4" holes are drilled through the plywood at the appropriate connection bolt slot in the crossmember for the hardware.

Column Filler Angle

The Column Filler Angle is used with 3/4" plywood to extend the top of a column 10" to 24" wide. It is placed in a run-by configuration when column dimensions are under 24".

Adjustable Column Extender

Steel plate assemblies overlap Steel-Ply forms to extend columns 2" to 12". They are used in a run-by configuration for column thicknesses from 10" to 22". The top angle of the plates have nail holes for connecting to deck plywood to facilitate monolithic deck and column pours.

Productive System

Gang forms are easily assembled on the ground and then moved into place. Stripping the unit as a gang eliminates rebuilding. This saves time and material, increases production, and reduces costs.

The lightweight Steel-Ply design is ideal for gangforming. At just 8 lbs. per square foot, including hardware, Walers and Strongbacks, gang form size is limited only by crane capacity.

Gang Form Bolt

Gang Form Bolts and Wedge Bolts are used to connect panels and gang form ties. The patented Steel-Ply Gang Form Bolt connects panel siderails and gang form ties in a single operation. This longer end allows you to break the ties back and strip the gang without disassembling the forms.

Waler

Walers are placed 18" from the top and bottom of the gang, with one Waler for each tier of panels. These Walers align forms within the gang. Walers are assembled using 2" x 4" or 2" x 6" lumber with Gang Waler Rods, Waler Plates, and 1/2" Contour Nuts for a secure connection.

Strongback

The same time and material advantages in waling with the Steel-Ply Forming System are also present in the use of Strongbacks which are needed only to align the Walers. They are usually placed at 8' centers, but spacing depends on the specific job conditions.

Steel-Ply Gang Filler

The Steel-Ply Gang Filler increases productivity by reducing the number of ties required in conventional gangforming. This 2" steel filler features preset tie hole locations for reusable 15mm Taper Ties (1" to 3/4"), She Bolts or Tie Rods with 15mm Tie Nuts to secure the tie.

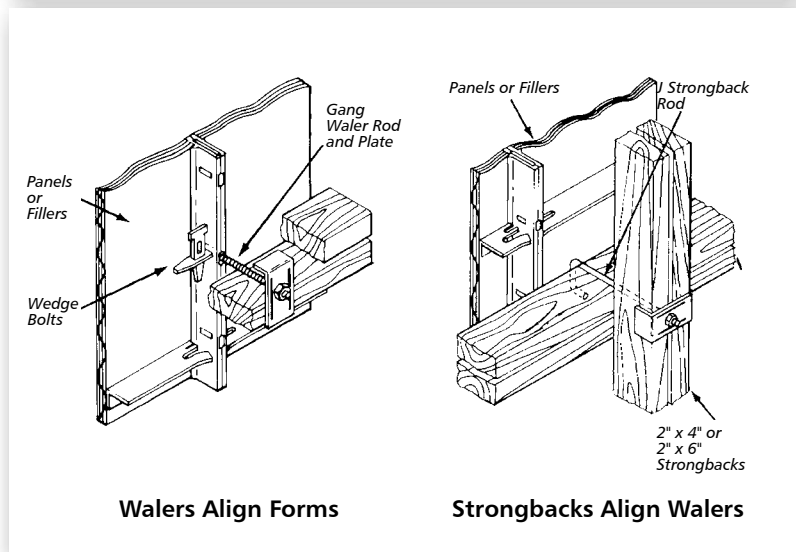



The most economical and productive way to gangform with Steel-Ply forming system is to use the load-gathering technique. Steel walers and strongbacks “gather” the load of the panels and high-capacity ties are installed through the panels and Walers. The load is transferred to the ties from the walers.

The strength and rigidity of the Steel-Ply system allows ties to be placed farther apart than in conventional gang forming. Fewer ties saves labor when setting, stripping and patching, and increases tie placement adaptability.

“Y” Walls

Load-gathered Steel-Ply reduces the number of ties, saving labor and material for typical “Y” walls. Standard Inside and Outside Corners and a Cantilever Bracket form trough walls. Inside and Outside Bay Corners and 45° Walers are combined with Walers and Waler Splices to form “Y” walls.

Heavy Duty Ties

Symons supplies 50 Kip She-Bolts or Taper Ties when 5" walers are used. The strength of these ties, combined with the load-gathering ability of the Steel-Ply panels and Walers, permit 4'x5' tie spacing in most gang form applications. Using fewer ties with each gang reduces overall labor and material costs. 85 Kip She-Bolts and 96 Kip Taper Ties are used with 8" walers.

65 Kip She-Bolts and Taper Ties are used with 5" or 8" Walers.

Spreader Clips

Spreader Clips are used with Taper Ties or She-Bolts. It is a U-shaped plate that fits over the Cast Bearing Washer and hex nut, preventing inward movement of the gang. A tie with Spreader Clips near the bottom of the forms and one tie with Spreader Clips near the top of the form prevents inward movement and maintains the desired wall thickness.

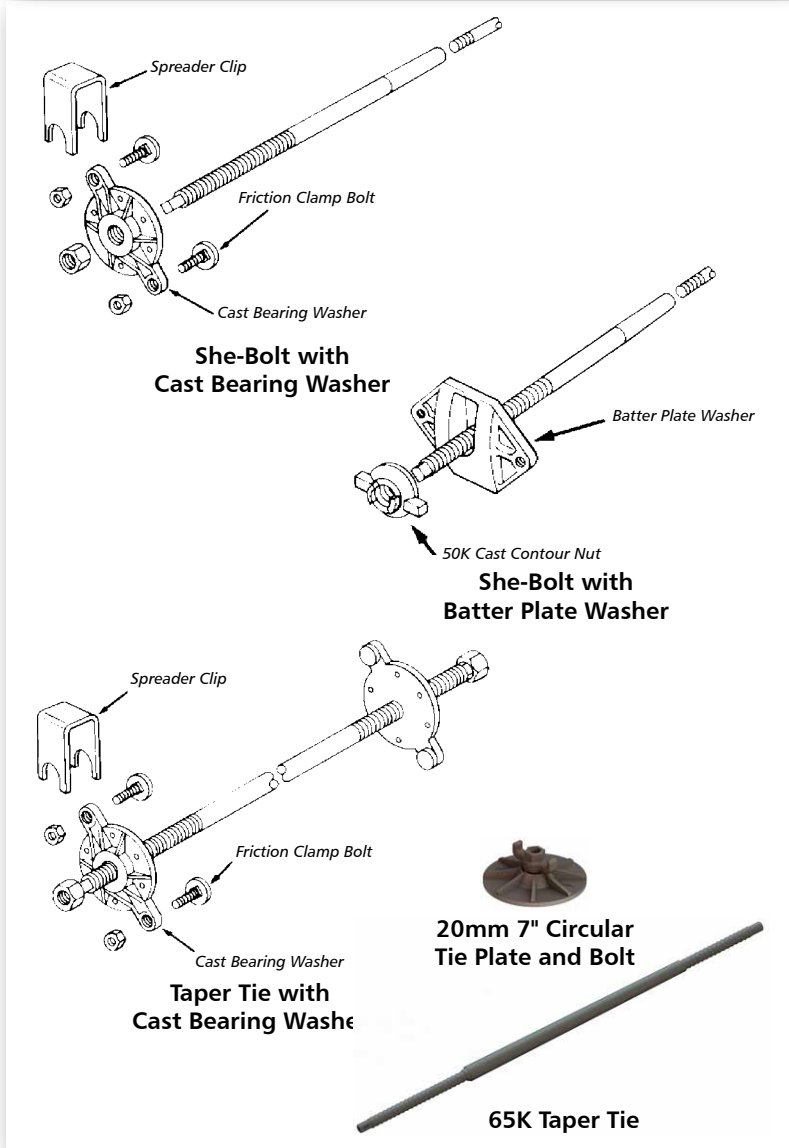

Maxi-Waler Steel Channel

The Maxi-Waler System uses double 3" steel channels attached to Steel-Ply at 2' O.C. vertical spacing. The channel serves as both load-gathering member and aligner for the gang. "L" Washers and 8" Gang Waler Rods secure the steel channels to the forms for a positive connection.

Vertical Walers

The Maxi-Waler System uses double channel steel walers to transfer the load from the 3" channels. J-Strongback Rods and Plate Washers connect to the 3" channels at specific vertical locations. To prevent slippage, Panel Waler Connectors and Clip Angles are bolted to the Waler at two connection sites. Walers are spaced at 4' centers for maximum form design utilization.

5" and 8" Steel Walers

For maximum form design utilization, Symons offers 5" and 8" waler sizes. Tie areas of up to 32 square feet can be achieved, resulting in fewer ties per pour and less tie patching.

The 5" and 8" walers are available in standard lengths of 4', 8', 10', 12' and 16'. The 5" walers are also available in a 6' length.

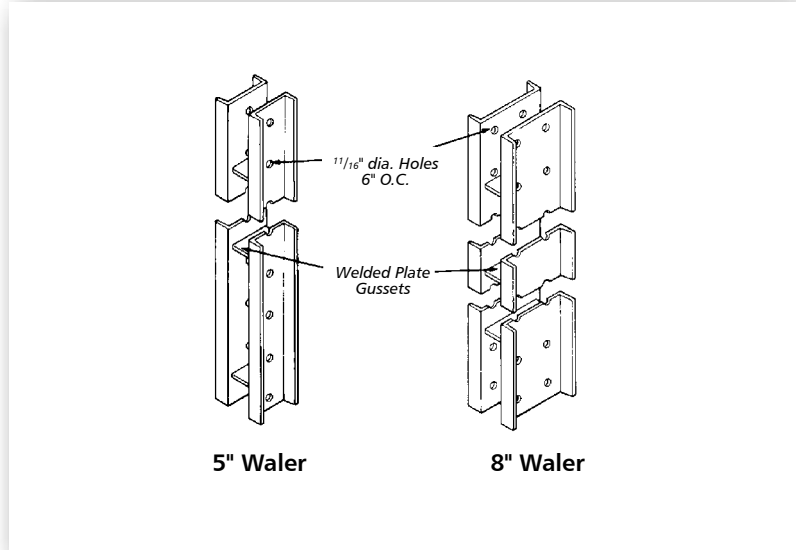
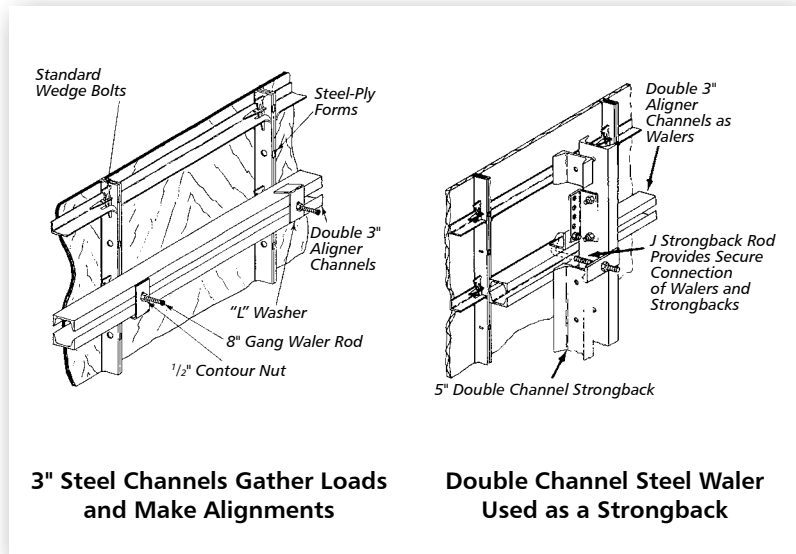

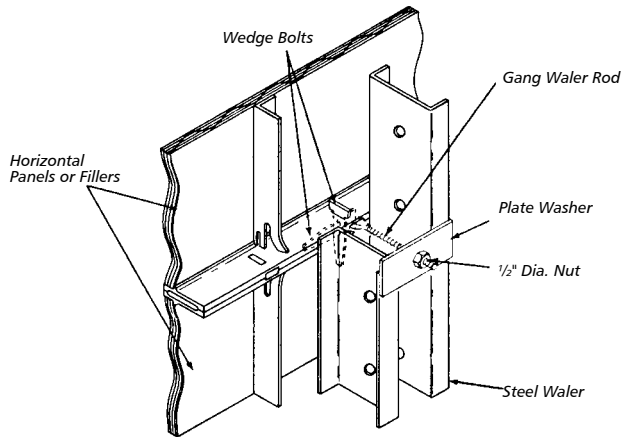

Typical Waler Connection

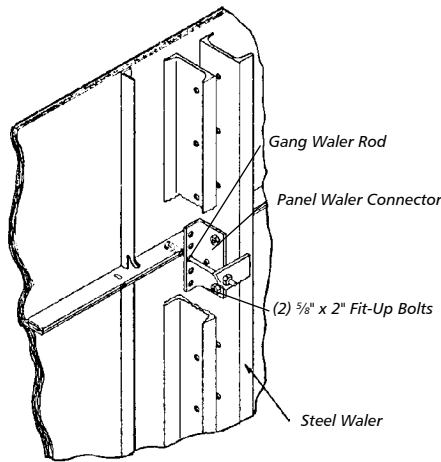

Panel Waler Connection

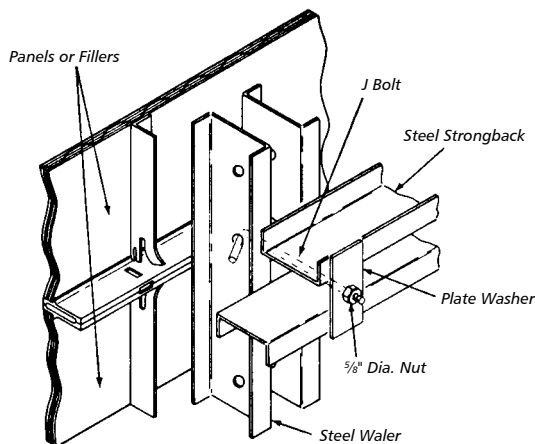

5" Versiform Walers Used as a Steel Strongback

Horizontal Steel-Ply Gangs

Horizontal Steel-Ply gang forms utilize vertical steel walers. This permits the use of high capacity Taper Ties or She-Bolts.

Horizontal Steel-Ply gangs are assembled using 6' and 3' panels in a "brick" pattern layout.

Waler Connection

Steel walers are easily connected with 8" Gang Waler Rods, Plate Washers and 1/2" diameter Contour Nuts. Walers are placed 18" from gang ends and at 3' O.C. spacing.

Panel Waler Connector

To prevent waler slippage, a Panel Waler Connector is attached through the Gang Waler Rod and bolted to the walers.

Panel Waler Connectors can also connect the horizontal Strongbacks to vertical steel Walers.

Strongback

5" Walers used as Strongbacks provide stiffness and horizontal alignment to the gang. These Walers are attached with 8 1/2" J-Bolts, Plate Washers and 5/8" Contour Nuts. Strongbacks are usually placed at the top and bottom of each gang.



Double Hinged Fillers

Double Hinged Fillers allow gangs for core walls and elevator shafts to be set, stripped, lifted and reset quickly. Minimal crane time is needed because they make all four sides of the gang into one movable unit.

The Double Hinged Filler is designed with two hinge points to permit inward movement when a Turnbuckle connection is retracted. After positioning the gang for the next pour, the Turnbuckles return the gang form to the rectangular shape.

Steel Walers and Strongbacks are used with high capacity She-Bolts or Taper Ties for higher productivity.

Multi Shear Wall Bracket

The Multi Shear Wall Bracket supports ganged forms for multiple lifts. Used with the Guide Bracket to position gangs snug against the wall, the Multi Shear Wall Bracket can support 3,000 lbs.

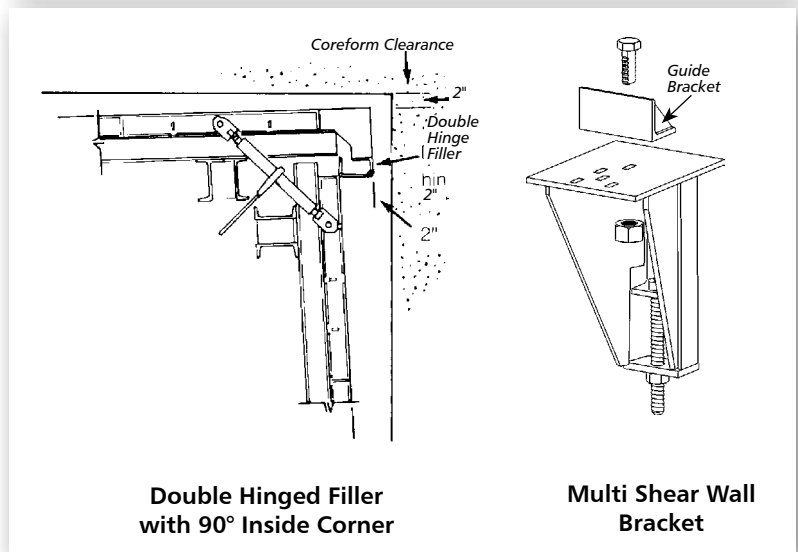
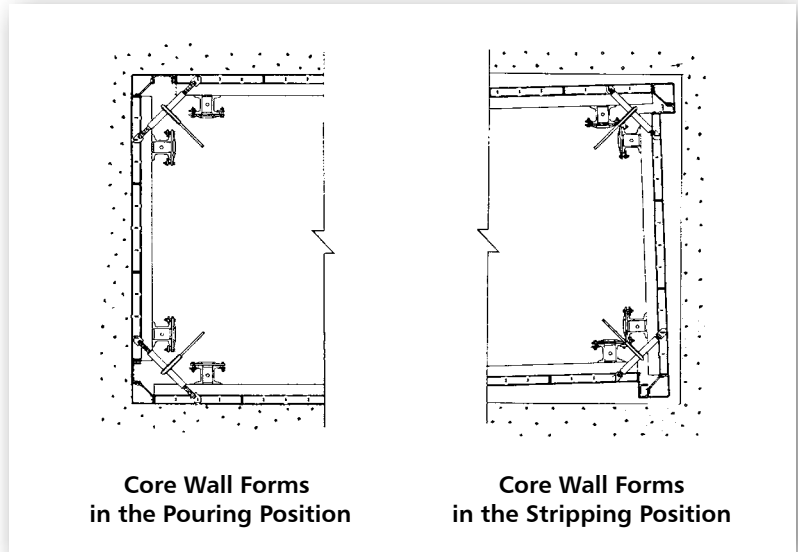

Curved Walls

The Steel-Ply forming system can be used more efficiently than conventional job-built forms for curved walls or tank structures. Two foot wide panels readily form curved walls down to a 15' inside radius (30' diameter). Standard fillers can be used to form smaller radius walls, for example 8" fillers are used to form a 5' radius. One inch, 1½" and 2" Fillers adapt to radius walls easily with no "cut-up" construction. A simple program is used to calculate the number and sizes of panels and filler needed. A layout will show where every piece is located on the curved wall.

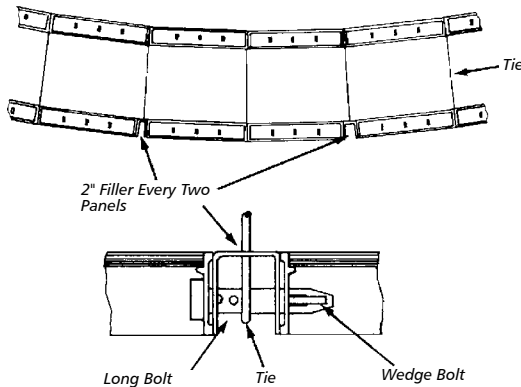

Curved Wall Forms Using Steel-Ply

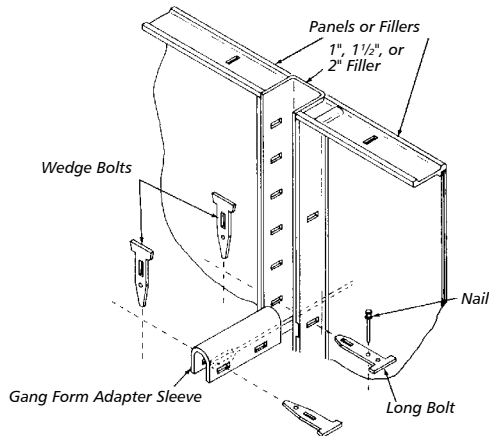

Gang Form Adapter Sleeve Attachment

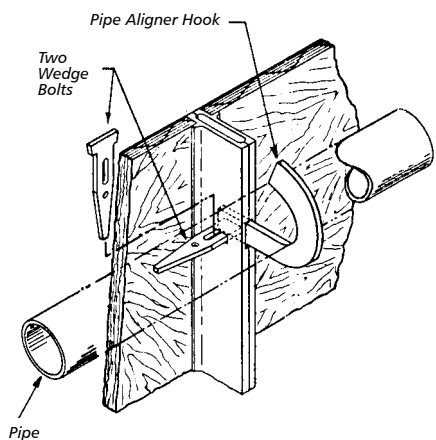

Typical Pipe Alignment



Transitions from Sym-Ply® to Steel-Ply

Wedge Bolts allow quick and easy connection between Steel-Ply and Sym-Ply. This combination allows contractors who own one or the other system to rent the other as needed.

Transitions from Steel-Ply to Max-A-Form® or Flex-Form®

Steel-Ply panels and fillers connect directly to Max-A-Form and Flex-Form with Wedge Bolts. This combination provides the strength and gang forming advantages of the all-steel systems with Steel-Ply versatility for details.



Sym-Ply to Steel-Ply Transition

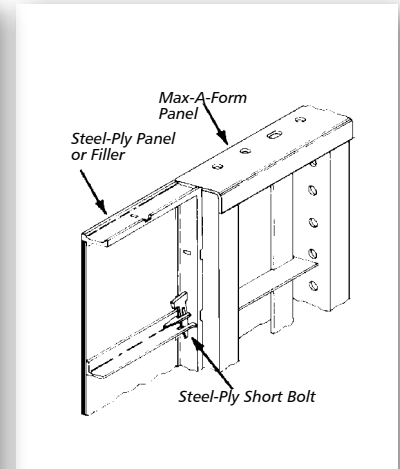

Steel-Ply to Max-A-Form Transition

Attached Hardware Option

Residential and other repetitive hand-set jobs are perfect applications for the time-saving attached hardware feature. In this system, panels are supplied with the connecting Drop Bolts and Slide Bolts already attached. Since connecting bolts are already attached at the tie locations, workers immediately know where to position each tie.

An attached Hardware Kit is also available for contractors who wish to retrofit Steel-Ply panels and fillers they already own.

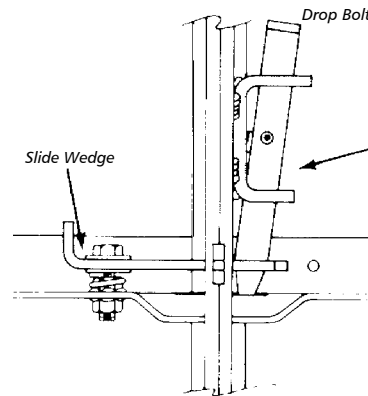

Attached Hardware in the Locked Position

Beam Pocket

The Beam Pocket is a reusable tapered steel boxout that leaves a void pocket at the top of the foundation wall for steel or wooden beams. The standard 6"x8"x4" deep size comes with a handle for easy carrying and removal.

For more information on Symons forming systems: www.daytonsuperior.com/forming or call 1-800-800-7966.

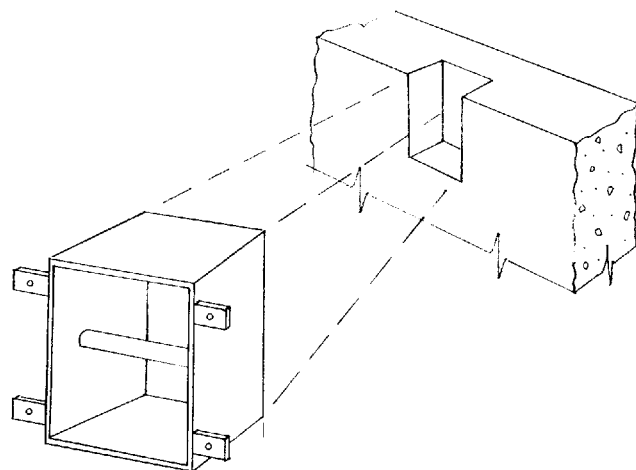

Beam Pocket for Foundation Void

DAYTON SUPERIOR BRANDS

CONCRETE ACCESSORIES

Accubrace[®]
 Aztec[®]
 Bar Lock[®]
 Corewall[®]
 Fleet-Lift[™]
 Swift Lift[®]
 Taper-Lock[®]

CONSTRUCTION CHEMICALS

Earth Friendly[®]
 Unitex[®]

FORMING PRODUCTS

Max-A-Form[®]
 Steel-Ply[®]
 Sym-Ply[®]
 Symons[®]

DAYTON SUPERIOR PRODUCTS

BRIDGE DECK FORMING

Adjustable Joist Hangers
 Bridge Overhang Brackets
 Haunch and Fillet Forming
 Pres-Steel, Coil Rod and Con-Beam
 Hangers
 Screed Supports

CHEMICALS

Bond Breakers
 Cleaners / Strippers
 Concrete Repair/Restoration
 Curing Compounds / Sealers
 Epoxies
 Floor Levelers
 Form Release Agents
 Grout
 Hardeners / Industrial Toppings
 Liquid Densifiers
 Surface Retarders

FORMING AND SHORING

Aluminum Shoring
 Ganged Formwork
 Garage Beam System
 Handset Formwork
 Highway Forms
 Jump Forms
 Modular Deck Shoring
 One Sided Frames
 Self Spanning Forms
 Steel Frame Shoring

FORMLINERS

ABS Plastic
 Polystyrene Plastic

PAVING

Dowel Bar Expansion Caps
 Dowel Bar Retrofit System
 Elastomeric and Hot Pour Joint Seal
 Metal Keyway Form Systems
 Tie Bar Assemblies
 Transverse Bar Assemblies
 Welded Dowel Assemblies
 Wire Baskets without Dowels

PRECAST

Anchors and Lift Systems
 Coil / Ferrule Inserts
 Core Plugs
 Magnets
 Precast Forms
 Rustications/Chamfers
 Sandwich Panel Connector
 Shear Connectors
 Slotted Inserts

REBAR SPLICING

Forged Dowel Bar Couplers
 Lockshear Bolt Couplers
 Shear Resistance Products
 Straight Thread Couplers
 Taper Thread Couplers

REBAR SUPPORTS

Concrete Dobbies
 Continuous Plastic and Steel
 Bar Supports
 Individual Plastic and Steel
 Bar Supports
 Mesh Chairs
 Paving Chairs
 Side Form Spacers

TIES AND ACCESSORIES

Modular Form Ties
 Single Waler System
 Ties and Accessories

TILT-UP

Braces and Brace Anchors
 Helical Ground Anchors
 Setting Plugs
 Strongback System
 Tilt-Up Anchors and Lifting Systems

CONTACT INFORMATION

CORPORATE HEADQUARTERS

1125 Byers Road
 Miamisburg, OH 45342
 937-866-0711

ACCESSORIES AND CHEMICALS

Customer Service: 888-977-9600
 Technical Assistance: 877-266-7732
 info@daytonsuperior.com

FORMING PRODUCTS

Customer Service: 800-800-7966
 Technical Assistance: 877-266-7732
 info@daytonsuperior.com

With products proudly made in America and a wide breadth of recognized brands, Dayton Superior is the most comprehensive, single-source provider for all your concrete construction needs.